



ZME_WCS1

Z-Wave Single Paddle Wall Controller DURO crema

Firmware Version : 1.2

Quick Start

S This device operates as Z-Wave sensor. The device operates in normal control mode or in management mode. Pushing all four buttons for 5 sec. will turn the device into management mode (indicated by blinking green LED). The management mode will time out after 10 seconds if no further button is pushed. Button 3 confirms standard inclusion or exclusion started by a primary controller, button 2 issues a Node Information Frame or wakeup notification, button 4 is used to add devices into association groups and button 1 confirms inclusion or exclusion in NWI (network wide inclusion) mode.

Please refer to the chapters below for detailed information about all aspects of the products usage.

What is Z-Wave?

This device is equipped with wireless communication complying to the Z-Wave standard. Z-Wave is the **international standard for wireless communication** in smart homes and buildings. It is using the **frequency of 868.42 MHz** to realize a very stable and secure communication. Each message is reconfirmed (**two-way communication**) and every mains powered node can act as a repeater for other nodes (**meshed network**) in case the receiver is not in direct wireless range of the transmitter.

Z-Wave differentiates between Controllers and Slaves. Slaves are either sensors (**S**) transmitting metered or measured data or actuators (**A**) capable to execute an action. Controllers are either static mains powered controllers (**C**) also referred to as gateways or mobile battery operated remote controls (**R**). This results in a number of possible communication patterns within a Z-Wave network that are partly or completely supported by a specific device.

1. Controllers control actuators
2. Actuators report change of status back to controller
3. Sensors report change of status of measured values to controller
4. Sensors directly control actuators
5. Actuators control other actuators
6. Remote controls send signals to static controllers to trigger scenes or other actions
7. Remote controls control other actuators.

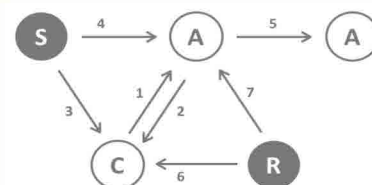

There are two different role a controller can have. There is always one single primary controller that is managing the network and including/excluding devices. The controller may have other functions - like control buttons - as well. All other controllers don't manage the network itself but can control other devices. They are called secondary controllers. The image also shows that its not possible to operate a sensor just from a remote control. Sensors only communicate with static controllers.

Product description

The Z-Wave.Me Wall Controller is a Z-Wave device that can both control other Z-Wave devices and activate predefined scenes in an IP gateway. Although it is controlling other devices, the Wall Controller cannot act as Z-Wave network controller (primary or secondary) and will always need a Z-Wave network controller to be included into a Z-Wave network. The device can be used in different modes that are selected by configuration parameters:

1. Control of groups of other Z-Wave devices using 'ON', 'OFF' and Dim commands.
2. Control of devices in proximity of the Wall Controller using 'ALL ON' or 'ALL OFF' commands.
3. Activation of predefined scenes in Gateways or other Z-Wave devices.

The device can be used with split paddles as well. Just remove the single paddle and mont the split paddle.

Batteries

The unit is operated by batteries. Use only batteries of correct type. Never mix old and new batteries in the same device. Used batteries contain hazardous substances and should not be disposed of with household waste!

Battery Type: 1 * CR2032

Installation Guidelines

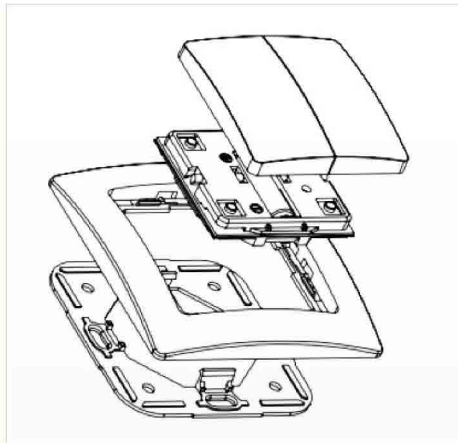

The device can be mounted on every dry and flat surface using either screws or double side adhesive. First the mounting base is fixed on the wall. Next step the switch frame is placed on the 2 frame and the electronic insert is used to fix the frame to the mounting base as shown on the image. Finally the switching paddle(s) are mounted on the electronic base.

For battery change, the switching paddle(s) need to be removed. The CR battery can be replaced by pushing the little nipple above the battery. The old battery will slide out and the new battery is inserted until the nipple will hold it again.

The device can be operated in two different modes:

- **Operation Mode:** This is the mode where the device is controlling other Z-Wave devices or is activating scenes.
- **Management Mode:** The device is turned into the management mode by pushing all four buttons for 5 sec. A blinking green LED indicates the management mode. In the management mode the buttons of the device have different functions. If no further action is performed, the device will turn back to the normal mode after 10 sec. Any management action terminates the management mode as well.

In management mode the following actions can be performed:

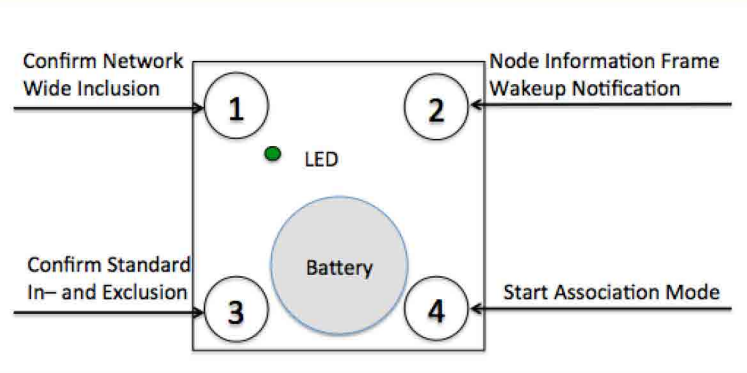

- Button 1 - Network Wide Inclusion: The device can be included into a Z-Wave network from any physical location in the network. This requires a primary controller supporting Explorer Frames. This mode lasts for 20 seconds and stops automatically. Any button press stops the mode as well.
- Button 2 - Send Node Information Frame and Wake up Notification. (See explanation in the respective chapters below)
- Button 3 – Standard Inclusion/Exclusion Mode: The device is included or excluded from a controller in direct wireless range. Any button press stops the mode. Performing an exclusion of the device from a network resets the device into its factory default.
- Button 4 - Association Set: To assign target devices to one of the four association groups. Refer to the manuals section about association for more information how to set and unset association groups.

Behavior within the Z-Wave network

I On factory default the device does not belong to any Z-Wave network. The device needs to join an existing wireless network to communicate with the devices of this network. This process is called **Inclusion**. Devices can also leave a network. This process is called **Exclusion**. Both processes are initiated by the primary controller of the Z-Wave network. This controller will be turned into exclusion respective inclusion mode. Please refer to your primary controllers manual on how to turn your controller into inclusion or exclusion mode. Only if the primary controller is in inclusion or exclusion mode, this device can join or leave the network. Leaving the network - i.e. being excluded - sets the device back to factory default.

If the device already belongs to a network, follow the exclusion process before including it in your network. Otherwise inclusion of this device will fail. If the controller being included was a primary controller, it has to be reset first.

Once the controller is turned into inclusion mode **turn the Wall Controller into management mode and hit button 3**. The **device is excluded by entering management mode and hitting button 3** when the controller is in exclusion mode. To include/exclude the device in the NWI mode **turn the Wall Controller into management mode and hit button 1**.

Wall Controller into management mode and hit button 1.

Operating the device

Depending on the button mode and command set configured the device can be used in different ways.

Button modes:

Control with two groups of two buttons (This is the default mode) One group (No. 1) of devices is controlled by button 1 and 3, the other group (No. 2) is controlled by button 2 and 4. Clicking the larger button turns the loads 'ON', clicking the smaller button turns the loads 'OFF'. If double clicks are enabled in configuration parameters #1 or #2, groups No. 3 and No. 4 are controlled by short double click of the buttons.

Dimming commands are sent by holding down the buttons (Dim UP using Buttons 1 and 2, Dim Down using Buttons 3 and 4) respective Click + Hold in case the double click option is enabled.

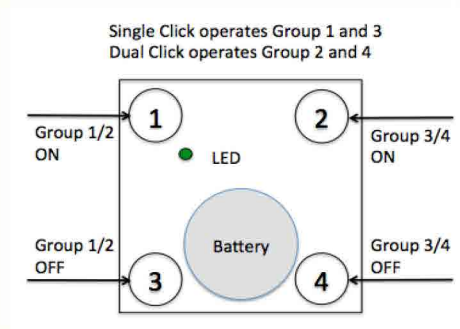

Control with single buttons In this mode a group of devices is controlled by a single button: single click turns 'ON'; double click turns 'OFF' devices in the group. In case dimmers are controlled, holding down the button will dim up, click and hold down will dim down the load. The group number corresponds to the button label.

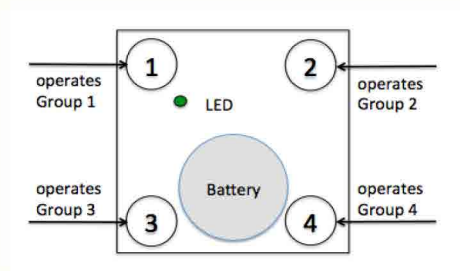

Control Commands:

The configuration parameter #11...#14 specifies what commands are sent when the buttons are operated.

Direct Control of associated devices using 'ON', 'OFF', 'DIM UP' and 'DIM DOWN' The special commands 'ALL ON' resp. 'ALL OFF' are sent as broadcast to all devices in direct wireless range. The devices act according to their individual settings for 'Switch ALL' commands. This mode implements the communication pattern 7.

Simple Scene Activation using configurable scene control commands.. Associated devices in an association group are controlled by individual commands defined by Z-Wave command class 'Scene Controller Configuration'. One scene number can be configured per association group. On default, the scene number equals the association group number as shown in the figure below. This mode implements communication patterns 6 and 7. This mode is typically used to activate scenes in IP gateways but can also be used to activate predefined scenes in other scene-capable devices.

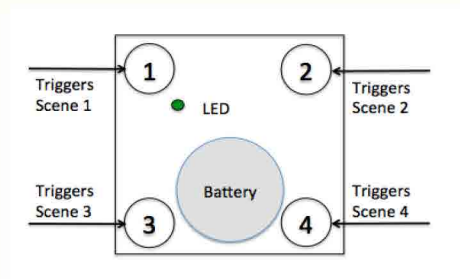

Enhanced Scene Activation:

In this mode every button action can issue a scene activation command with a dedicated number. The scene number is a combination of the group number and the action performed on the button and has always two digits. The group number defines the upper digit of the scene number, the action the lower digit. The following actions are possible:

- 1 = On
- 2 = Off

- 3 = Dim Up Start
- 4 = Dim Down Start
- 5 = Dim Up Stop
- 6 = Dim Down Stop

Example: Clicking/double clicking the button 1 will issue a scene activation command for scene 11 (button 1 click, event on) and scene 12 (button double click 1, event off, single button control is used in this example). This mode implements the communication pattern 6.

Child Protection

The device can be turned into a child protection mode. In this mode all local operation is disabled.

The device can be turned into a child protection mode. In this mode all local operation is disabled. The child protection mode MUST be turned on wirelessly. However, in protected by sequence mode it is possible to unlock the device for local operation by pressing any button for 5 seconds. The unlock state will last for 5 seconds.

Wakeup Intervals - how to communicate with the device?

W This device is battery operated and turned into deep sleep state most of the time to save battery life time. Communication with the device is limited. In order to communicate with the device, a static controller **C** is needed in the network. This controller will maintain a mailbox for the battery operated devices and store commands that can not be received during deep sleep state. Without such a controller, communication may become impossible and/or the battery life time is significantly decreased.

This device will wakeup regularly and announce the wakeup state by sending out a so called Wakeup Notification. The controller can then empty the mailbox. Therefore, the device needs to be configured with the desired wakeup interval and the node ID of the controller. If the device was included by a static controller this controller will usually perform all necessary configurations. The wakeup interval is a tradeoff between maximal battery life time and the desired responses of the device.

The device will stay awake right after inclusion for 2.5 seconds allowing the controller to perform certain configuration actions. It is possible to manually wake up the device by pushing button 2 in management mode.

The minimum allowed wakeup time is 240s but it is strongly recommended to define a much longer interval since the only purpose of a wakeup should be the reporting of the battery status or an update of the child protection settings. Defining Node ID of 0 as a destination of the Wakeup Notification will disable the periodical wakeup function entirely.

It is possible to set the node ID to 255 to send wakeup notifications as broadcast. In this mode device takes more time to go to sleep and drains battery faster, but can notify all its direct neighbors about a wakeup.

Node Information Frame

NI The Node Information Frame is the business card of a Z-Wave device. It contains information about the device type and the technical capabilities. The inclusion and exclusion of the device is confirmed by sending out a Node Information Frame. Beside this it may be needed for certain network operations to send out a Node Information Frame.

Pressing Button 2 in management mode will issue a Node Information Frame.

LED Control

1. Confirmation - green 2 sec
2. Failure - red 2 sec
3. Button press confirmation - green 1/4 sec
4. Waiting for Network Management mode selection - green blinks
5. Waiting for group selection in Association Set Mode - green fast blink
6. Waiting for NIF in Association Set Mode - green-red - off blink

Associations

A Z-Wave devices control other Z-Wave devices. The relationship between one device controlling another device is called *association*. In order to control a different device, the controlling device needs to maintain a list of devices that will receive controlling commands. These lists are called **association groups** and they are always related to certain events (e.g. button pressed, sensor triggers, ...). In case the event happens all devices stored in the respective association group will receive a common wireless command.

Association Groups:

1	Controlled by button 1 or single clicks of buttons 1 and 3 (max. nodes in group: 8)
2	Controlled by button 3 or double clicks of buttons 1 and 3 (max. nodes in group: 8)
3	Controlled by button 2 or single clicks of buttons 2 and 4 (max. nodes in group: 8)
4	Controlled by button 4 or double clicks of buttons 2 and 4 (max. nodes in group: 8)

Set and unset associations to actuators

Associations can be assigned and remove either via Z-Wave commands or using the device itself.

SA

To control a Z-Wave device from the Wall Controller the node ID of this devices needs to be assigned to one of the four association groups. This is a three-step process:

1. Turn the Wall Controller into management mode and hit button 4 within 10 sec. (LED is blinking green when management mode is reached).
2. Within 10 sec. push the button you like the Z-Wave actuator to be assigned with. After 10 sec. the devices goes back to sleep. **Single click means adding to this association group, double click means removing the node selected** in step (3) from this association group.
3. Find the Z-Wave actuator you like to control by the Wall Controller. Hit the button on the device to issue a Node Information Frame within 20 sec. A common way is hitting a control button one or three times. Please consult the manual of the device to be controlled for more information how to issue an Node Information Frame. Any button press on Wall Controller at this stage will terminate the process.

Configuration Parameters

Z-Wave products are supposed to work out of the box after inclusion, however certain configuration can adapt the function better to user needs or unlock further enhanced features.

IMPORTANT: Controllers may only allow to configure signed values. In order to set values in the range 128 ... 255 the value sent in the application shall be the desired value minus 256. For example: to set a parameter to 200 it may be needed to set a value of 200 minus 256 = minus 56. In case of two byte value the same logic applies: Values greater than 32768 may needed to be given as negative values too.

Button 1 and 3 pair mode (Parameter Number 1, Parameter Size 1)

In separate mode button 1 works with group 1, button 3 with groups 3. Click is On, Hold is dimming Up, Double click is Off, Click-Hold is dimming Down. In pair button 1/3 are Up/Down correspondingly. Click is On/Off, Hold is dimming Up/Down. Single clicks works with group 1, double click with group 3.

Value	Description
0	Separately
1	In pair without double clicks (Default)
2	In pair with double clicks

Button 2 and 4 pair mode (Parameter Number 2, Parameter Size 1)

In separate mode button 2 works with group 2, button 4 with groups 4. Click is On, Hold is dimming Up, Double click is Off, Click-Hold is dimming Down. In pair button 2/4 are Up/Down correspondingly. Click is On/Off, Hold is dimming Up/Down. Single clicks works with group 2, double click with group 4.

Value	Description
0	Separately
1	In pair without double clicks (Default)
2	In pair with double clicks

Action on group 1 (Parameter Number 11, Parameter Size 1)

In Switch On/Off only mode On command is sent on Dim Up, Off on Dim Down. In Scenes mode the scene ID sent is (10 * group + ActionID), where ActionID is: 1 = On, 2 = Off, 3 = Dim Up Start, 4 = Dim Down Start, 5 = Dim Up Stop, 6 = Dim Down Stop

Value	Description
0	Disabled
1	Switch On/Off and Dim (send Basic Set and Switch Multilevel) (Default)
2	Switch On/Off only (send Basic Set)
3	Switch All
4	Send Scenes
5	Send Preconfigured Scenes

Action on group 2 (Parameter Number 12, Parameter Size 1)

In Switch On/Off only mode On command is sent on Dim Up, Off on Dim Down. In Scenes mode the scene ID sent is (10 * group + ActionID), where ActionID is: 1 = On, 2 = Off, 3 = Dim Up Start, 4 = Dim Down Start, 5 = Dim Up Stop, 6 = Dim Down Stop

Value	Description
0	Disabled
1	Switch On/Off and Dim (send Basic Set and Switch Multilevel) (Default)

2	Switch On/Off only (send Basic Set)
3	Switch All
4	Send Scenes
5	Send Preconfigured Scenes

Action on group 3 (Parameter Number 13, Parameter Size 1)

In Switch On/Off only mode On command is sent on Dim Up, Off on Dim Down. In Scenes mode the scene ID sent is (10 * group + ActionID), where ActionID is: 1 = On, 2 = Off, 3 = Dim Up Start, 4 = Dim Down Start, 5 = Dim Up Stop, 6 = Dim Down Stop

Value	Description
0	Disabled
1	Switch On/Off and Dim (send Basic Set and Switch Multilevel) (Default)
2	Switch On/Off only (send Basic Set)
3	Switch All
4	Send Scenes
5	Send Preconfigured Scenes

Action on group 4 (Parameter Number 14, Parameter Size 1)

In Switch On/Off only mode On command is sent on Dim Up, Off on Dim Down. In Scenes mode the scene ID sent is (10 * group + ActionID), where ActionID is: 1 = On, 2 = Off, 3 = Dim Up Start, 4 = Dim Down Start, 5 = Dim Up Stop, 6 = Dim Down Stop

Value	Description
0	Disabled
1	Switch On/Off and Dim (send Basic Set and Switch Multilevel) (Default)
2	Switch On/Off only (send Basic Set)
3	Switch All
4	Send Scenes
5	Send Preconfigured Scenes

Typical click timeout (Parameter Number 20, Parameter Size 1)

Typical time used to differentiate click, hold and double clicks

Value	Description
1 — 100	in 10ms units (Default 50)

Send the following Switch All commands (Parameter Number 21, Parameter Size 1)

Value	Description
1	Switch off only (Default)
2	Switch on only
255	Switch all on and off

Invert buttons (Parameter Number 22, Parameter Size 1)

Value	Description
0	No (Default)
1	Yes

LED confirmation mode (Parameter Number 24, Parameter Size 1)

This allows to save battery

Value	Description
0	No confirmations
1	Confirm button press

2 Confirm button press and delivery (Default)

Send unsolicited Battery Report on Wake Up (Parameter Number 30, Parameter Size 1)

Value	Description
0	No (Default)
1	To same node as wake up notification
2	Broadcast to neighbours

Command Classes

Supported Command Classes

- Basic (version 1)
- Battery (version 1)
- Wake Up (version 2)
- Association (version 2)
- Version (version 1)
- Multi Channel (version 3)
- Multi Channel Association (version 2)
- Configuration (version 1)
- Manufacturer Specific (version 1)
- Protection (version 1)
- Node Naming and Location (version 1)
- Multilevel Switch (version 1)
- Scene Activation (version 1)
- All Switch (version 1)
- Scene Controller Configuration (version 1)

Controlled Command Classes

- Basic (version 1)
- Multi Channel (version 3)
- Multilevel Switch (version 1)
- Scene Activation (version 1)
- All Switch (version 1)

Technical Data

IP Rating	IP 20
Battery Type	1 * CR2032
Frequency	868.42 MHz (SRD Band)
Wireless Range	up to 100 m outside, on average up to 20 m inside buildings
Explorer Frame Support	Yes
SDK	4.54.01
Device Type	Slave with routing capabilities
Generic Device Class	Remote Switch
Specific Device Class	Multilevel Remote Switch
Routing	No
FLiRS	No

Explanation of Z-Wave specific terms

- **Controller** — is a Z-Wave device with capabilities to manage the network. Controllers are typically Gateways, Remote Controls or battery operated wall controllers.
- **Slave** — is a Z-Wave device without capabilities to manage the network. Slaves can be sensors, actuators and even remote controls.
- **Primary Controller** — is the central organizer of the network. It must be a controller. There can be only one primary controller in a Z-Wave network.
- **Inclusion** — is the process of bringing new Z-Wave devices into a network.
- **Exclusion** — is the process of removing Z-Wave devices from the network.
- **Association** — is a control relationship between a controlling device and a controlled device.
- **Wakeup Notification** — is a special wireless message issued by a Z-Wave device to announce that it is able to communicate.
- **Node Information Frame** — is a special wireless message issued by a Z-Wave device to announce its capabilities and functions.

Disposal Guidelines

The product contains batteries. Please remove the batteries when the device is not used.

Do not dispose of electrical appliances as unsorted municipal waste, use separate collection facilities. Contact your local government for information regarding the collection systems available. If electrical appliances are disposed of in landfills or dumps, hazardous substances can leak into the groundwater and get into the food chain, damaging your health and well-being.

Технологии беспроводного умного дома «DomZWave»
197374, РФ, г.Санкт-Петербург, ул. Оптиков, д.4
umnyj@dom-z-wave.ru
dom-z-wave.ru